



ParLite Led Strobe

Product code: PC10016A196

KEY FEATURES

- Thick aluminium, long lasting light source in long lasting body
- 7 Led rings individually controlled
- Strobe and Wash modes (automatic LED intensity adjustment)
- Beam angle: 120°
- Low noise applications, silent fan
- Guaranteed flicker-free operation (DMX controlled PWM frequency)
- Cosmetic design for hi-end installation, only 4.5 Kg (9.9 lbs)
- Internal/External gel frame (standard size)
- Smart build "Quick Stand" tucked into yoke



SPECIFICATIONS

- Fixed white CCT: 6.500 K
- Beam angle: 120°
- 7 LED rings individually controlled
- 'Ring' strobe effects
- Strobe and Wash modes (automatic LED intensity adjustment)
- Electronic strobe, synchronized, random, pulse effect
- Electronic dimmer (2 different curves selectable)
- Flicker-free operation with LED frequency controlled by DMX from 600 to 5.000 Hz
- Double yoke for easy ground standing or truss hanging
- IP rating: 20 or 65 (weatherproof)

LIGHT SOURCE

- 308 Seoul LEDs Daylight
- Average LED lifetime: a minimum of 80% of the initial luminous flux will be maintained after approx. 50.000 hours of usage (50.000 LM80)

PHYSICAL SIZE

- Length: 211 mm (8.3 in)
- Width: 182 mm (7.1 in)
- Height: 267 mm (10.5 in)
- Weight: 4.5 Kg (9.9 lbs)

CONTROL PROTOCOL AND PROGRAMMING

- USITT DMX512A
- DMX Channels: 13 / 6 / 3
- Setting and addressing: binary dip switch or remotely
- RDM (Remote Device Management)

ELECTRICAL SPECIFICATIONS AND CONNECTIONS

- AC power: 90-250 V, auto-sensing, 50/60 Hz, 2 m (6.6 ft) integral cable without power plug
- Power consumption: 0.7 A at 230 V, 1.5 A at 115 V
- DMX data in/out: 5 pin locking XLR

ACCESSORIES

- Support color frame holder
- Frame for internal frost filter
- Frame for external frost filter
- 4 leaf barndoor

DRAWING SIZE

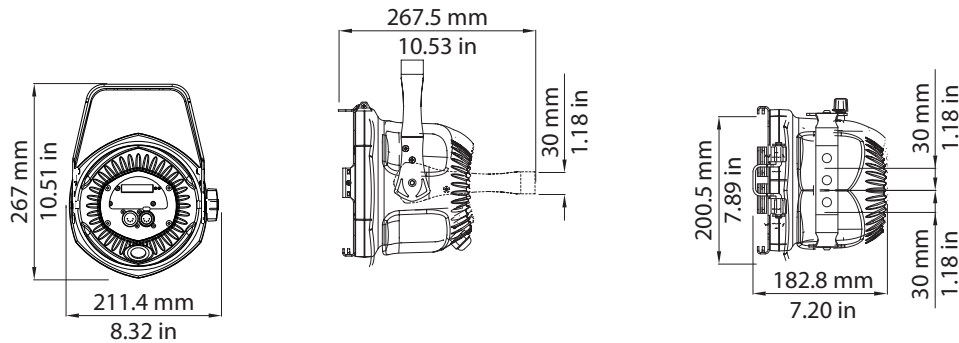

DMX CHARTS

13 channels		6 channels		3 channels	
1	master dimmer	1	master dimmer	1	master dimmer
2	ring 1	2	frequency	2	frequency
3	ring 2	3	duration	3	duration
4	ring 3	4	strobe effect		
5	ring 4	5	games		
6	ring 5	6	game speed		
7	ring 6				
8	ring 7				
9	frequency				
10	duration				
11	strobe effect				
12	games				
13	game speed				

PHOTOMETRIC DATA

The ParLite Led Strobe Photometric Data may be downloaded from www.coemar.com.

ACCESSORIES

Code	Description
BC10007A001	Support color frame holder black
BC10007A002	Support color frame holder silver
PC09164	4 leaf barndoor
PC09169	Frame for internal frost filter
PC09169/1	Frame for external frost filter